

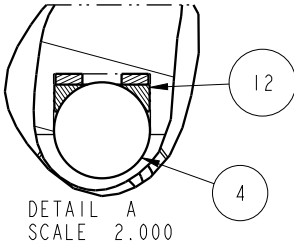

NO	QTY	PART NO	DESCRIPTION	STD SEAL KIT	FKM SEAL KIT
1	1	21500010	SCREW, CAP, BTNH, M12 X 20, ALY		
2	2	21500019	SCREW, CAP, BTNH, M3 X 6, ALY		
3	2	21500200	WASHER		
4	3	23600002	BALL, STEEL, ALLOY, .250	X	X
5	1	39011030	SEAL,CROWN,1-1/16x1-1/4x5/32	X	39V11030
6	1	39011046	SEAL,BEVEL W/HEEL INSERT,7/8 x1/8 x1 1/8	X	39V11046
7	2	39051076	O-RING, (6mm x 2)	X	39V51076
8	1	39053000	WIPER,SNAP-IN, (7/8)	X	X
9	2	43068006	PLUG, PORT, HOLLOW HEX, G1/4		
10	1	47511313	PLUNGER,SC,HS,11.6KN,LH,LS		
11	1	81400030	RETAINER,SC,HS,2600		
12	3	90199958	ASSY,BALLSEAT,SC,2600/5000	X	X
13	1	39F54002	BU RING, (-212 CUSTOM)	X	X
14	1	39T55003	GASKET, (-124)		
N/A	N/A	60414503	KIT, SEAL, STANDARD		
N/A	N/A	6V414503	KIT, SEAL, FKM		

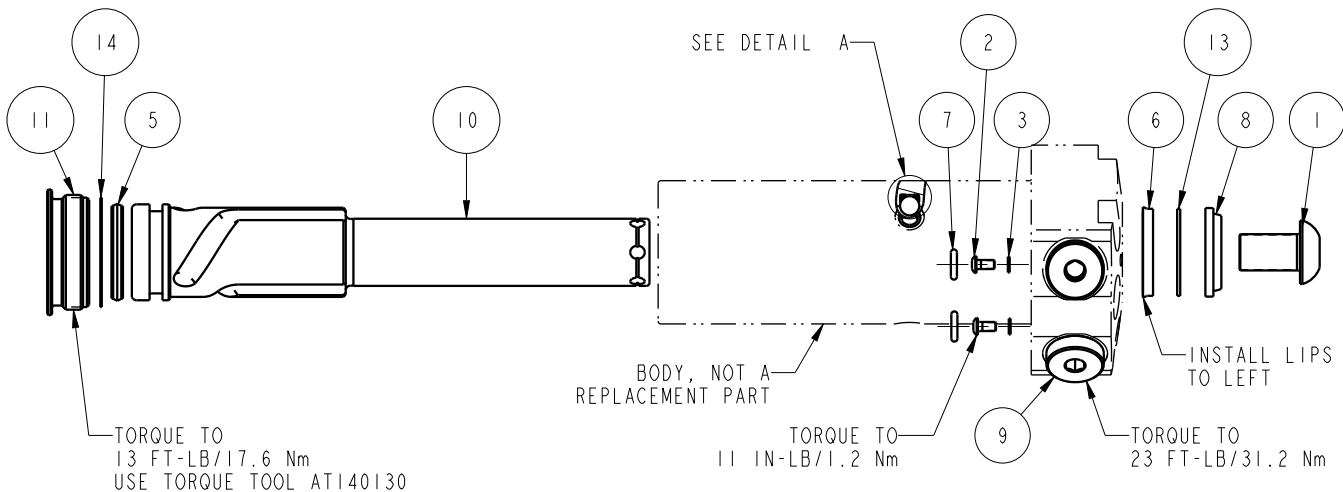

PARTS LIST	 VEKTEK VEKTEK, INC. 1334 E. SIXTH AVE. P.O. BOX 625 EMPORIA, KS. 66801 U.S.A.
	ASSEMBLIES AFFECTED PARTS LIST, ASSY, SC, TF, TC, 11.6KN, DA, LH, LS 41461124
SIZE A	MPLV1422
REV D	REV D

D	5279	RELEASE	ALS	4/25/24
REV	IN ACCORDANCE WITH ECN	EFFECTIVE DATE	REVISED BY	DATE
DRW BY:	DRAWING STATUS: Released			
DATE: 11/30/11	PRODUCTION APPROVED FOR RELEASED STATUS ONLY			